

# DIGITAL VARIABLE AREA FLOWMETER (ROTAMETER)

## ORIGIN OF METAL TUBE ROTAMETER

It operates on the principle of variable area; the fluid in the metal tube raised a float in the taper tube increasing the area of passage of fluid.

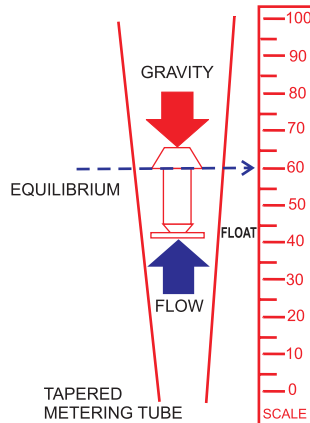

The float moves up in proportion to the rate of flow of fluid and get stabilized when the weight of the float is balanced by the upward hydraulic force. By a magnetic coupling the inner float movement through a series of linkages and counter weight. The tube and the float combination determine the flowrate.

**DIGITAL METER:** The inner float magnetic field is detected by the high sensitive magnetic field detection sensor, enable us to show the digital readout.

As such this flowmeter does not require any electrical connection, since it operates on battery. It has an inbuilt two wire transmitter provide 24 VDC and take 4 – 20 mA signal.

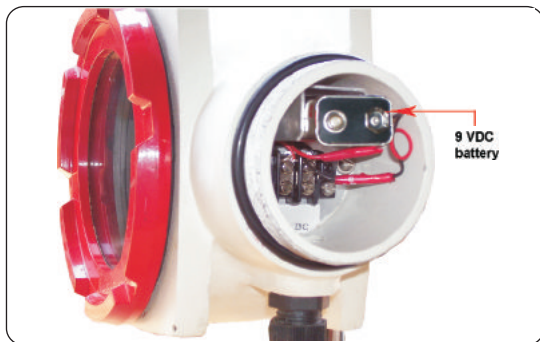

## BENEFITS OF SPINK CONTROLS DIGITAL VARIABLE AREA FLOW METERS

- Local indication without the need for auxiliary power.
- Minimum pressure loss.
- Easy to read.
- Accurate measurement even at higher flow(150 m<sup>3</sup>/hr).
- Suitable for low flow (8LPH)
- Default inbuilt transmitter of 4 – 20 mA (Loop powered).
- No movement assembly reducing the maintenance.

## TECHNICAL SPECIFICATION

Accuracy	: +/- 1.5% of FSR.
Rangeability	: 10:1
Repeatability	: +/- 0.25% of FSR
Temperature Rating	: -50 to 120°C
Pressure Rating	: 80 kg/cm <sup>2</sup>
Flow Direction	: Bottom to Top
End connection	: Flanged to suit customer's requirement.
Wetted Part	: To suitable specific liquid or gases.
Mounting position	: Vertical.
Indication	: Digital flow rate
Transmission	: 2 wire loop powered
Enclosure	: Flameproof / Weatherproof.
Power supply	: 9 VDC Battery

## MAXIMUM FLOW AND PRESSURE LOSS

LINE SIZE NB	20°C WATER FLOW m <sup>3</sup> /hr	0°C 1 atm AIR FLOW Nm <sup>3</sup> /hr	APPROX PRESSURE LOSS MM WC
15	0.2 - 1.2	6 - 35	200 - 225
20	0.4 - 2.0	8 - 60	220 - 230
25	1 - 5	30 - 150	200 - 270
40	2.5 - 10	70 - 300	200 - 250
50	3.5 - 17	100 - 500	225 - 280
85	6 - 30	200 - 900	225 - 240
80	10 - 45	300 - 1200	225 - 280
100	20 - 100	600 - 3000	350 - 850
125	30 - 120	900 - 4000	300 - 850
150	30 - 150	900 - 4500	350 - 950

R-1 A,VILAS APPT, SANT TUKARAM  
PATH,KOPRI, THANE(E) 400 603,INDIA  
Fax: 91-22-2532 4845

**SPINK CONTROLS**

Phone:91-22-2532 8223/24 Email:info@spinkcontrolsindia.com  
www.spinkcontrolsindia.com

®

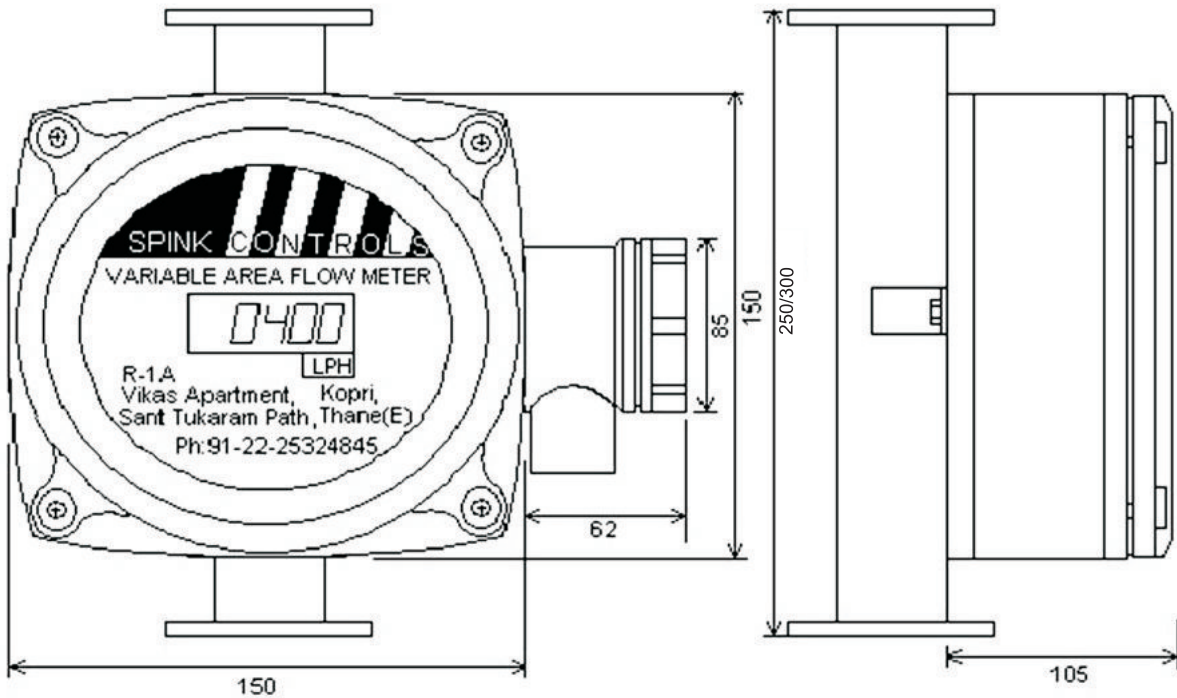

<b>MODEL CODE</b>		<b>R 300/D</b>	
LOCAL INDICATOR LCD 1/2" DISPLAY AND BATTERY OPERATED		0001	
LOCAL INDICATOR AND TOTALISER (16X2 LINE) WITH LOOP POWERED		0002	
LOCAL INDICATOR WITH LED 1/2" DISPLAY 230VAC INPUT AND 4-20 mA OUTPUT		0003	
LOCAL INDICATOR WITH 1" LED DISPLAY 230VAC INPUT AND 4-20 mA OUTPUT.		0004	
LOCAL INDICATOR WITH TOTALISER AND BATCH CONTROLLER (16X4 LINE) LCD DISPLAY, 230VAC INPUT.		0005	
LOCAL INDICATOR WITH TOTALISER AND DENSITY CORRECTION FACILITY		0006	
LOCAL INDICATOR WITH HIGH/LOW SWITCH		0007	
<b>MATERIAL OF CONSTRUCTION (WETTED PARTS)</b>			
SS 304		304	
SS 304 WITH TEFLONLINED		316	
SS 316		PP	
SS 316 WITH TEFLONILINED		PVC	
PP		304PTFE	
PVC		316PTFE	
INDICATOR HOUSING: DIE-CAST ALUMINUM			AL
INDICATOR HOUSING: SS 304			SP
<b>MATERIAL FOR FLOAT</b>			
SS 316			1
TEFLON			2
PVC			3
<b>ADDITIONAL ACCESSORIE</b>			
JACKETING			J
REMOTE TOTALISER 230 VAC			IN
REMOTE TOTALISER AND CONTROLLER 110 VAC			INC
<b>EXAMPLE</b>	<b>R-300/D/</b>	<b>001/ 304/</b>	<b>AL/ 01/ IN</b>

# Electromagnetic Flowmeter



## Introduction

Spink introduces new range of Plastic Body Electromagnetic Flowmeters for the first time in India.

These Flowmeters will help you reduce your cost and at the same time giving performance as that of metallic body Flowmeters. It is suitable for pipes with diameters of 10 mm to 150 mm. The meter features flanged construction. It has excellent accuracy and flow rangeability. The meter is suitable for use on wide range of corrosive and aggressive range of conductive liquids.

## Salient Features

- Entire Plastic body Construction therefore rust free
- Light Weight
- Suitable for Virtually all types of Conductive Liquids
- Easy installation and absolutely low maintenance
- Remote Transmitter Type Assembly
- Coil Assembly in hermetically sealed Welded construction
- Suitable for pipe sizes of diameters 10 mm to 150 mm
- Field interchangeable electronics
- No pressure loss
- Excellent Accuracy and Repeatability
- **Performance at par with metallic body Flowmeters but at much lower Cost**

## Applications

- Chemical, Petrochemical and Process Industries
- Fertilizer Industries
- Pharmaceutical Industry
- Food Industry
- Drug Industries
- Sugar Industries
- Beverage Industries
- Paper and Pulp Industries
- Aluminum Industries
- Steel Industries
- Mining Industries
- Dredging Industries
- Water and Waste - Water Management
- And many others

## Operations

Electromagnetic Flowmeters are based on Faraday's law of Electromagnetic Induction.

In a Electromagnetic Flowmeter, magnetic field is generated by a set of coils. As the conductive liquid passes through the electromagnetic field, an electric voltage is induced in the liquid, which is directly proportional to its velocity. This induced voltage is perpendicular to both the liquid flow direction and the electromagnetic field direction. The voltage sensed by the electrodes is further processed by the transmitter to standardised output signal or displayed in appropriate Engineering Units on LED Display.

# Electromagnetic Flowmeter

## Specifications

Suitable for Pipe Sizes	: DN 10 to DN 150
Media Conductivity (Min.)	: 10 $\mu$ S/cm
Media Pressure	: 5 kg/cm <sup>2</sup>
Media Temperature	: 0 - 55 C
Ambient Temperature Range	: 0 - 50 C
Materials : Pipe	: HDPE
Electrode	: SS / Hastelloy C / Ta / Ti / Pt
End Connections / Flanges	: HDPE
Coil Housing	: HDPE
Transmitter	: Cast Aluminium (LM4) , Epoxy painted
Flange / End Connection Std.	: DIN / ANSI / BS
Power Supply	: 110 / 240V AC $\pm$ 15%, 50Hz
Power Consumption	: 20 VA
Cable Gland Entry	: 1/2" NPT (F) : For Transmitter and PG9 for Junction Box
Analog Output (Isolated)	: 4-20 mA DC / 0-20 mA DC
Pulsed Output (Optional)	: Low Pulsed Rate Output 10 to 36000 pulses per hour a) Output to drive directly external electromagnetic counter of 12/24V DC @ 200 mA capacity OR b) Open Collector Output , High Pulse Rate Output, 0.5 KHz/1 KHz/10KHz/ (Open Collector Output)
Communication Port (Optional)	: RS - 232 / RS - 485 MODBUS RTU Protocol
Maximum Load Resistance	: 1000 $\Omega$
Response Time	: 5 seconds
Flow Velocity Range	: 0.3 to 10 m/s
Ingress Protection	: IP - 65 (IP - 68 on request)
LED Display	: 4 Digit Indication for Flow Rate and 8 Digit Indication for Totaliser
Programming	: From Front Keyboard for Engineering Units
Accuracy	: $\pm$ 1% of measured value
Reference Conditions	
Power Supply	: Nominal
Ambient Temperature	: 2 $\text{^\circ}$ $\pm$ 2 C
Load Resistance	: 500 $\Omega$
Repeatability	: $\pm$ 0.2% of span
Effect of Ambient Temperature	: Less than 0.2% per 10 $\text{^\circ}$ C
Effect of Power Supply	: Less than 0.1% per 10% Voltage variation
Effect of Load Resistance	: Less than 0.1% of span

## Meter Dimensions

DN (mm)	A	B	C	D
10, 15, 20	65	200	120	190
25, 32	80	200	150	205
40, 50	120	200	225	245
65, 80	130	200	245	255
100, 125	170	250	325	295
150	190	300	365	315

Notes : 1. Above dimensions are with ANSI 150  
( For other flanges - Consult Factory )  
2. Add 10 mm for two SS 316 Earthing rings and rubber gaskets to dimension 'B'

## Dimensional Drawing :

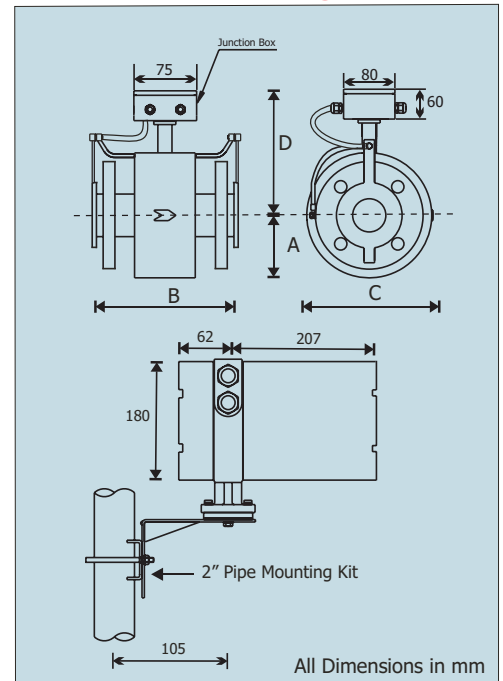

## Ordering Information

### POWER SUPPLY

- 1) 240 +/- 15% V AC 50 Hz
- 2) 110 +/- 15% V AC 50 Hz

### FLOW METER SIZE

- 1) DN 10
- 2) DN 15
- 3) DN20
- 4) DN 25
- 5) DN 32
- 6) DN 40
- 7) DN 50
- 8) DN 65
- 9) DN 80
- 10) DN 100
- 11) DN 125
- 12) DN 150

### FLANGE STANDARDS

- 1) DIN PN 40
- 2) DIN PN 16
- 3) DIN PN 10
- 4) ANSI 300
- 5) ANSI 150
- 6) Any other

### OUTPUT SIGNAL

- 1) 4-20 mA DC
- 2) 0-20 mA DC

### ELECTRODE

- 1) SS 316
- 2) Hastelloy C
- 3) Tantalum
- 4) Titanium
- 5) Platinum
- 6) Any other

### PULSED OUTPUT (Optional)

- 1) Low Pulse output
- 2) High Pulse output
- 3) Nil

### COMMUNICATION PORT (Optional)

- 1) RS-232
- 2) RS-485

R-1 A,VILAS APPT, SANT TUKARAM  
PATH,KOPRI, THANE(E) 400 603,INDIA  
Fax: 91-22-2532 4845



# THE NEED FOR EVERY INDUSTRY

An ISO 9001:2008 Certified Company

## Fluid Flute(Averaging Pitot Tube)



R-1 A,VILAS APPT, SANT TUKARAM  
PATH,KOPRI, THANE(E) 400 603,INDIA  
Fax: 91-22-2532 4845

**SPINK CONTROLS**®

Phone:91-22-2532 8223/24 Email:info@spinkcontrolsindia.com  
www.spinkcontrolsindia.com

The pitot tube produces a Differential pressure (DP) signal proportional to the square of the flow rate in accordance with Bernoulli's theorem. This signal has two components, the high pressure (HP) and the low pressure (LP).

$$DP = HP - LP$$

When the fluid impacts the sensor, it creates a high pressure zone, greater than pipe static pressure, in front of the sensor. As the fluid moves past the sensor, it accelerates and a low pressure zone is created to the sides and rear of the sensor. Multiple sensing ports are positioned in the high and low pressure zones and an averaged differential pressure is produced. The DP increases proportionally to the square of the velocity of the fluid.



### TECHNICAL SPECIFICATION

Line size	: 150 NB – 750 NB (6" to 30")
Mounting	: Sensor Fitted With Flange and Fixed to Mounting Flange on Pipeline
Optional Insert	: Isolation Valve / Retract Mechanism

### Equations to Calculate Differential Pressure in mm of H<sub>2</sub>O.

1. Liquid (Volume rate of flow)\*

$$\Delta P = (SG_1) \left[ \frac{m^3 / hr}{0.000396 K D^2} \right]^2$$

2. Liquid & Gas (Mass rate of flow)\*

$$\Delta P = (1/\delta) \left[ \frac{kg / hr}{0.0125 K D^2} \right]^2$$

3. Gas (Standard Volume rate of flow)\*

$$\Delta P = \left[ \frac{T SG_2}{P} \right] \left[ \frac{Nm^3 / hr}{0.0191 K D^2} \right]^2$$

4. Gas (Actual volume rate of flow)\*

$$\Delta P = (SG_2) \left[ \frac{Am^3 / hr}{0.0125 K D^2} \right]^2$$

$\Delta P$  = dp in mm of H<sub>2</sub>O

m<sup>3</sup> / hr = cubic meter per hour

kg / hr = Kilogram per Hour

Nm<sup>3</sup> / hr = Normal cubic meter per Hour

Am<sup>3</sup> / hr = Actual cubic meter per Hour

K = Flow Coefficient of Averaging Pitot Tube

D = Pipe ID in mm

A = Cross Section area in m<sup>2</sup>

V = Flow Velocity in m/s

$\delta$  = Flow Density in Kg/m<sup>3</sup>

For Gas

$$\delta = \frac{P \times 289 \times 1.225}{101.35 \times T}$$

1.225 air density at 15°C and 101.35 KPa

T = °C + 273

P = KPa (ab)

SG<sub>1</sub> = Specific Gravity of Liquid

SG<sub>2</sub> = Specific Gravity of Gas

\*Thermal Expansion factor of CS pipe = 1 between 0 to 40°C

\*Gas Expansion factor assumed to be 1.0 to calculate  $\Delta P$

## Approximate Flow Rate of Water and Air\* with indicated differential pressure for Nominal Pipe size (SCH 40, SCH STD)

NB	Pipe ID	Water	$\Delta P$	Air	K
inch	mm	m <sup>3</sup> / hr	mmc WC	SCFM	
6	154	260	1168	4295	0.624
8	202.7	350	1109	5846	0.646
10	254.5	470	752	7836	0.668
12	303.2	580	563	9791	0.671
14	333.3	700	550	11815	0.678
16	381	820	437	13838	0.682
18	428.6	950	362	16037	0.686
20	477.8	1080	299	18216	0.690
24	574.6	1290	202	21779	0.694
30	742.95	1700	119	28686	0.712

\*Air Flow at 15°C and 101.35 KPa

## Fluid Flute for Air Duct

Equations to Calculate Differential Pressure, Volume Flow & Velocity

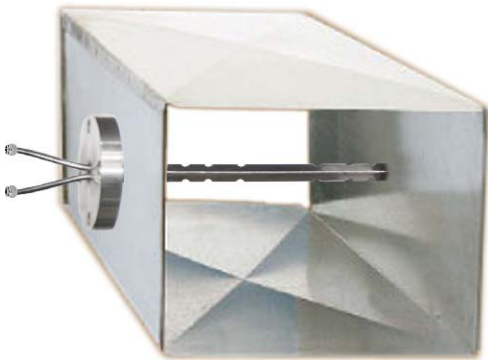

$$\Delta P = (\delta) \left[ \frac{V}{4.43 K^*} \right]^2 \text{ mm of H}_2\text{O}$$

$$Q = A \times V \times 3600 \text{ m}^3 / \text{hr}$$

$$V = 4.43 \times K^* \sqrt{\Delta P / \delta}$$

\* Equivalent Round Diameter of Rectangular Duct =  $\sqrt{1.27 \times W \times H}$

Where W & H are in inches. This D can be used to find K from above table



**Head Office**

R-1 A, VILAS APARTMENT,  
SANT TUKARAM PATH,  
KOPRI, THANE(E) - 400 603  
MAHARASHTRA, INDIA  
Fax : +91 22 2532 4845  
Phone : +91 22 2532 8223  
          +91 22 2532 8224  
Email : info@spinkcontrolsindia.com

**Branch Office ( Hyderabad )**

HOUSE No.1/2/241/1  
DOMALGUDA GAGANMAHAL ROAD,  
HYDERABAD-500029  
Phone : +91 9014887013  
Email : mahadev@spinkcontrols.com

**Branch Office ( Gujrat )**

SF-201, "SUNRISE COMPLEX"  
2nd FLOOR, NEAR VRUNDAVAN  
CHAR RASTA, WAGHODIA ROAD  
VADODARA, GUJRAT-390019  
Phone : +91 265 2525201  
Email : baroda@spinkcontrolsindia.com



Phone:91-22-2532 8223/24      Email:info@spinkcontrolsindia.com  
www.spinkcontrolsindia.com

# FOR ACCURATE AND ECONOMICAL MEASUREMENT & CONTROL OF FLUID FLOW.

## GLASS TUBE ROTAMETER



SPINK CONTROLS offer an Industrial flowmeter used to measure flowrate of liquids and gases. It operates on the Variable Area Principle, where the fluid flow raises a float in a taper tube, increasing the area of passage of fluid. The greater the flow, the higher the float is raised. The height of the float is raised by a combination of the buoyancy of the liquid and velocity head of the fluid. With gases, the buoyancy is negligible, and the float responds to the velocity head alone.

The taper glass tube is formed of Borosilicate glass of extremely high accuracy of bore, obtained by collapsing the taper tube while in a hot and plastic state on a precision ground and polished mandril. The tubes are then annealed in a furnace to relieve the stress formed during manufacturing.

Floats of various configurations and materials are used for a wide range of applications depending upon flowrate, viscosity, and turbidity of the fluid. The float has a sharp metering edge where the reading is observed by means of a scale mounted along the side of the tube. The scale of the rotameter is calibrated to directly read the fluid flow. The flowrate for any variable area flowmeter can be expressed as

$$Q = C D_f \sqrt{F/Y}$$

Q: Volumetric flowrate D : Diameter of float

C: Flow co-efficient : Density of Liquid.

F: Downward force of float

# Technical Data

Accuracy	: +/- 2% of FSR
Repeatability	: +/- 0.25% of FSR
Rangeability	: 10:1
Maximum Operating Temperature	: 150 C
Body	: MS Powder Coated.
Flow Direction	: From Bottom to Top
End Connection	: Flanged / Screwed as per Customers Specification.
Material Of Wetted Parts	: C.S. / S.S. 304 / S.S. 316 / P.P. / P.V.C. / Teflon.
Metering tube	: Borosilicate Glass, Resistant to high temperature.
Float	: SS304/SS 316 and others depending Upon type of Fluid.
Mounting Position	: Vertical
Elastomers	: Neoprene / Silicon / Viton / PTFE.

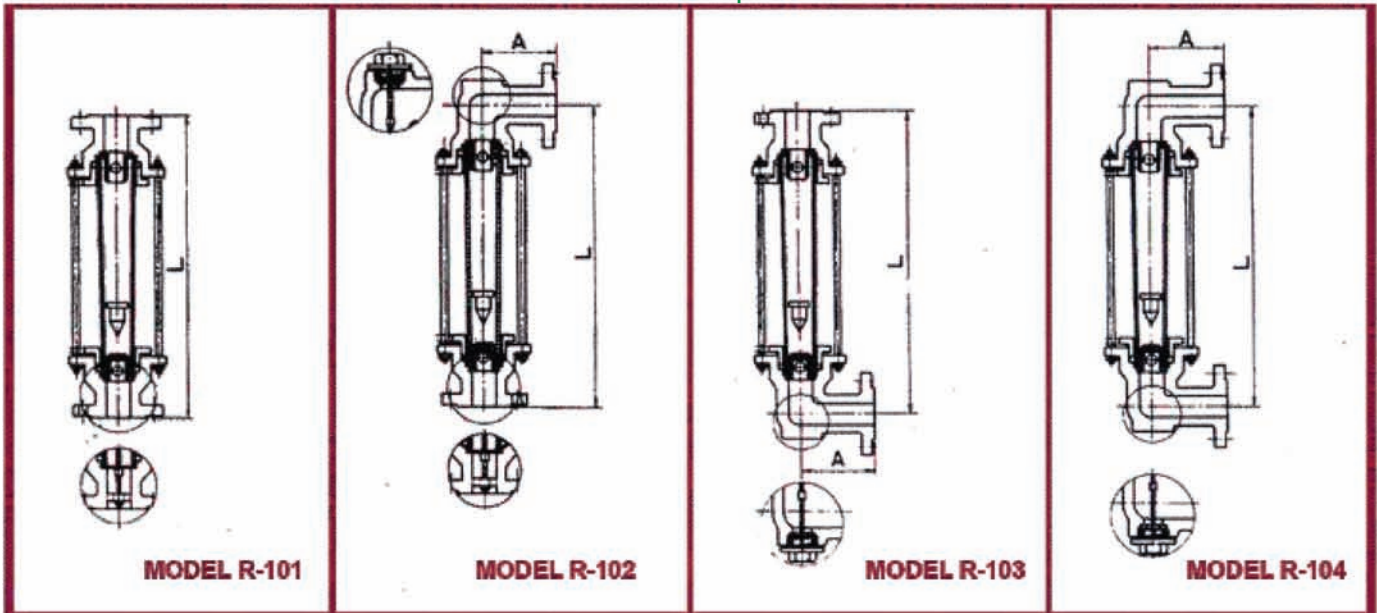

## Flow and dimension table by size Model R-101, 102, 103, 104

Standard Size	20°C water Maximum flow and pressure loss				0° C 1atm air maximum flow and pressur loss			Dimensions		
	Flow l/h			Approx Pressure loss mm. Aq (Float SS)	Flow Nm³/h			Approx Pressure loss mm. Aq (Float SS)	L mm	A mm
	Float material				Float material					
	SS	PVC	Teflon		SS 316	PVC	Teflon			
1/2"(15A)	430	250	250	200-300	—	7.1	6.51	50-150	500	75
3/4"(20A)	1100	740	740	220-370	11-35	20.50	26	120-200	500	100
1"(25A)	1890	1200	1250	200-550	540	32	37	120-200	500	100
	2500	2100	2100	250-550	75	44	56	160-210	500	100
1 1/2"(40A)	4400	3500	3500	250-600	145	83	100	160-210	500	120
2"(50A)	9100	7000	7000	250-650	299	168	260	160-210	500	120
	12100	10100	10100	350-700	415	230	340	140-220	500	140
2 1/2"(65A)	15000	13200	13200	350-950	520	440	500	140-250	500	140

R-1 A, VILAS APPT, SANT TUKARAM PATH, KOPRI, THANE(E) 400 603, INDIA  
 Fax: 91-22-2532 4845

Phone: 91-22-2532 8223/24      Email: info@spinkcontrolsindia.com  
 www.spinkcontrols.com      www.spinkcontrolsindia.com

# Electromagnetic Flowmeter 6400

## MagFlow 6410 (Full Bore Type)

### Measuring your Liquid Flow

---



Integral Type



Remote Type



---

## Introduction

Series 6400 is a new range of Bipolar Pulsed DC Full Bore Type Electromagnetic Flowmeters. It is suitable for pipes with diameters of 10 mm to 600 mm. They are based on Faraday's law of Electromagnetic Induction. The meter features flanged construction and is available with choice of Liner and Electrode materials. Series 6400 has excellent accuracy and flow rangeability. The meter is suitable for use on wide range of corrosive and aggressive range of conductive liquids.

## Salient Features

- Based on Faraday's law of Electromagnetic Induction.
- Suitable for pipe sizes of diameters 10 mm to 600 mm
- Coil Assembly in hermetically sealed Welded construction
- Choice of PTFE / Neoprene Rubber / Polyurethane liners
- Integral or Remote Transmitter
- Field interchangeable electronics
- Optional LED display for Flow Rate or Totaliser indication in Engineering Units
- No pressure loss
- High linearity due to characteristic magnetic field
- Absolute Zero stability and noise elimination
- Measurement independent of liquid properties

## Applications

- Chemical, Petrochemical and Process Industries
- Fertilizer Industries
- Pharmaceutical Industry
- Food Industry
- Drug Industries
- Sugar Industries
- Beverage Industries
- Paper and Pulp Industries
- Aluminum Industries
- Steel Industries
- Mining Industries
- Dredging Industries
- Water and Waste - Water Management
- And many others

# Operations

Electromagnetic Flowmeters are based on Faraday's law of Electromagnetic Induction.

In a Electromagnetic Flowmeter, magnetic field is generated by a set of coils. As the conductive liquid passes through the electromagnetic field, an electric voltage is induced in the liquid, which is directly proportional to its velocity. This induced voltage is perpendicular to both the liquid flow direction and the electromagnetic field direction. The voltage sensed by the electrodes is further processed by the transmitter to give standardised output signal or displayed in appropriate Engineering Units on LED Display.

The flux density of the electromagnetic field in a given Flowmeter and the distance between the electrodes are constant, therefore, the induced voltage is only a function of liquid velocity.

$$E = K.B.v.D \text{ where } E : \text{Induced voltage}$$

K : Flow Tube Constant

B : Magnetic field velocity

v: Mean flow velocity

and D : Electrode Spacing

Volume flow is calculated by equation :

$$Q = \bar{v}.D^2.\pi/4$$

Therefore,  $Q = \frac{E.D. \pi}{K.B.4}$

The induced voltage is not affected by the physical properties of liquid like temperature, viscosity, pressure, density and conductivity, as long as conductivity of the measure liquid is above minimum threshold level. For reliable measurement the pipe must be completely full of liquid.

The electromagnetic field coil assembly is excited by pulsed DC technique, which eliminates the interfering noise and provides automatic zero correction.

# Specifications

Suitable for Pipe Sizes	:	DN 10 to DN 600
Media Conductivity (Min.)	:	10 $\mu$ S/cm (Consult factory for 5 $\mu$ S/cm)
Media Pressure	:	PN 40 upto DN 80, PN 16 upto DN 200, PN 10 upto DN 600
Media Temperature (PTFE)	:	0°- 180C with Remote transmitter
	:	0°- 120C with Integral transmitter
	:	0°- 90C max for other liners
Ambient Temperature Range	:	0°- 50°C
Materials : Pipe	:	SS 316 (Non - magnetic )
Liner	:	PTFE / Neoprene / Polyurethane
Electrode	:	SS / Hastelloy C / Ta / Ti / Pt
End Connections / Flanges	:	Carbon Steel / SS 304 / SS 316 / SS 316L
Coil Housing	:	Carbon Steel / SS, Epoxy painted
Transmitter	:	Cast Aluminium (LM6) , Epoxy painted
Flange / End Connection Std.	:	DIN / ANSI / BS / SMS / TRI-CLAMP
Power Supply	:	110 / 240V AC $\pm$ 15%, 50Hz
Power Consumption	:	20 VA
Cable Gland Entry	:	1/2" NPT (F)
Analog Output (Isolated)	:	4-20 mA DC / 0-20 mA DC
Pulsed Output (Optional)	:	Low Pulsed Rate Output 10 to 36000 pulses per hour
		a) Output to drive directly external electromagnetic counter of 12/24V DC @ 200 mA capacity OR
		b) Open Collector Output , High Pulse Rate Output, 0.5 KHz/1 KHz/10KHz/ (Open Collector Output)
Communication Port (Optional)	:	RS - 232 / RS - 485 MODBUS RTU Protocol
Maximum Load Resistance	:	1000 $\Omega$
Response Time	:	5 seconds
Flow Velocity Range	:	0.3 to 10 m/s
Ingress Protection	:	IP - 65 (IP - 68 on request)
LED Display	:	4 Digit Indication for Flow Rate and 8 Digit Indication for Totaliser
		Programming from Front Keyboard for Engineering Units
Accuracy	:	$\pm$ 0.5% of measured value (calibrated) at reference conditions
For Flow between 20 to 100%	:	$\pm$ 1% of measured value (normal)
For Flow between 0 to 20%	:	Refer Error Diagram below
Reference Conditions		
Power Supply	:	Nominal
Ambient Temperature	:	25 $\pm$ 2 C
Load Resistance	:	500 $\Omega$
Repeatability	:	$\pm$ 0.2% of span
Effect of Ambient Temperature	:	Less than 0.2% per 10C
Effect of Power Supply	:	Less than 0.1% per 10% Voltage variation
Effect of Load Resistance	:	Less than 0.1% of span

## Error Diagram :

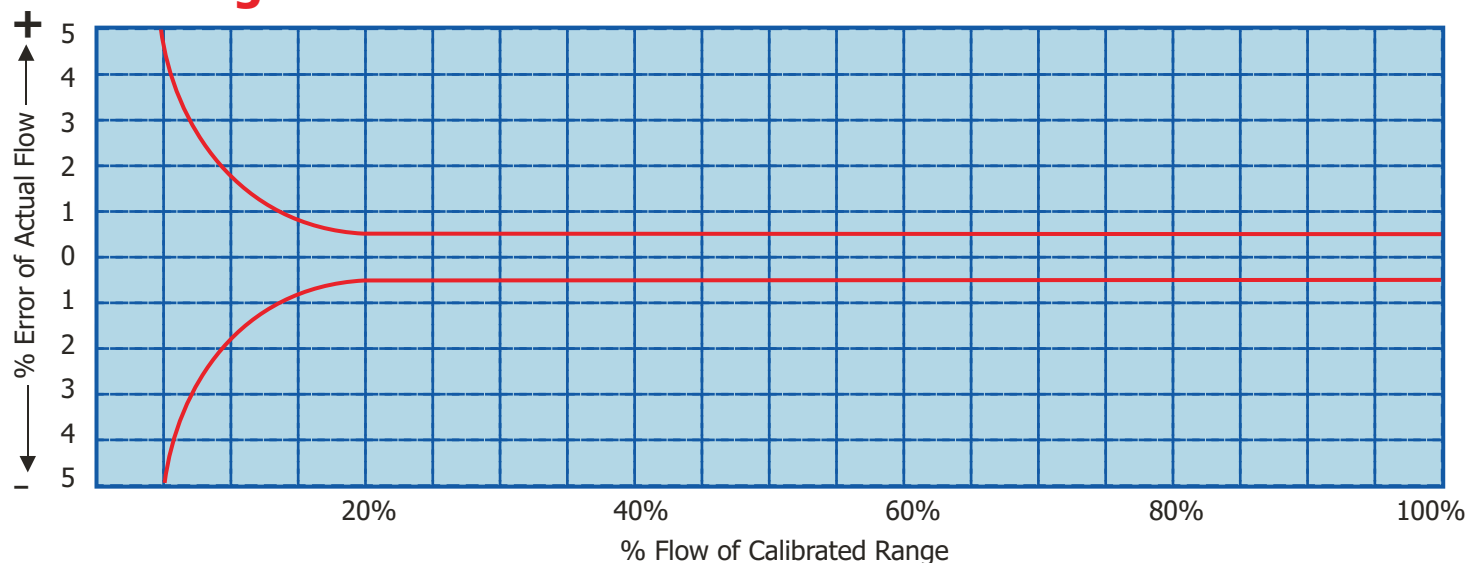

## Flow Rate Table

Flow Rate at V = 1 m/Sec.

DN	m <sup>3</sup> /Hr	LPM	LPS	DN	m <sup>3</sup> /Hr	LPM	LPS
10	0.282	4.711	0.078	125	44.18	736.198	12.270
15	0.636	10.601	0.176	150	63.61	1060.125	17.668
20	1.130	18.846	0.314	200	113.08	1884.667	31.411
25	1.766	29.447	0.490	250	176.69	2944.792	49.080
32	2.909	48.247	0.804	300	254.43	4240.500	70.675
40	4.523	75.386	1.256	350	346.31	5771.792	96.197
50	7.068	117.791	1.963	400	452.32	7538.668	125.645
65	11.944	199.100	3.317	450	572.47	9541.980	159.036
80	18.092	301.546	5.025	500	706.75	11779.169	196.321
100	28.270	471.166	7.852	600	1017.72	16962.003	282.702

## Ordering Information

### POWER SUPPLY

- 1) 240 +/- 15% V AC 50 Hz
- 2) 110 +/- 15% V AC 50 Hz

### FLOW METER SIZE

- 1) DN 10
- 2) DN 15
- 3) DN20
- 4) DN 25
- 5) DN 32
- 6) DN 40
- 7) DN 50
- 8) DN 65
- 9) DN 80
- 10) DN 100
- 11) DN 125
- 12) DN 150
- 13) DN 200
- 14) DN 250
- 15) DN 300
- 16) DN 350
- 17) DN 400
- 18) DN 450
- 19) DN 500
- 20) DN 600
- 21) Any other

### LINER MATERIAL

- 1) Teflon (PTFE)
- 2) Neoprene
- 3) Hard Rubber
- 4) Polyurethane
- 5) Any other

### ELECTRODE MATERIAL

- 1) Stainless Steel 316
- 2) Hastelloy C
- 3) Tantalum
- 4) Titanium
- 5) Platinum
- 6) Any other

### FLANGE / END CONNECTIONS STANDARDS

- 1) DIN PN 40
- 2) DIN PN 16
- 3) DIN PN 10
- 4) ANSI 300
- 5) ANSI 150
- 6) Tri-clamp
- 7) Any other

### FLANGE / END CONNECTIONS MATERIAL

- 1) Carbon Steel
- 2) Stainless Steel 304
- 3) Stainless Steel 316
- 4) Any other

### COIL HOUSING

- 1) Carbon Steel
- 2) Stainless Steel 304
- 3) Stainless Steel 316

### FLOW TRANSMITTER

- 1) Integral without Display
- 2) Integral with Display
- 3) Remote with Display
- 4) Remote without Display

### OUTPUT SIGNAL

- 1) 4-20 mA DC
- 2) 0-20 mA DC

### PULSED OUTPUT (Optional)

- 1) Low Pulse output
- 2) High Pulse output
- 3) Nil

### COMMUNICATION PORT (Optional)

- 1) RS-232
- 2) RS-485

- Notes :**
- 1) Flowmeter is supplied with 2 Nos. of SS 316 Earthing Rings of 3 mm thickness.
  - 2) Remote Flow Transmitter is supplied with 2" Pipe Mounting Kit and 10 meter each electrode signal cable and coil supply cable.
  - 3) Installation location should be such that the Flowmeter will always remain full with liquid.
  - 4) A minimum 5D upstream and 3D downstream straight lengths should be maintained at installation location. where D is the pipe diameter. The Flowmeter installation location should be free of bends, elbows, tees, valves etc.

# Dimensional Drawing :

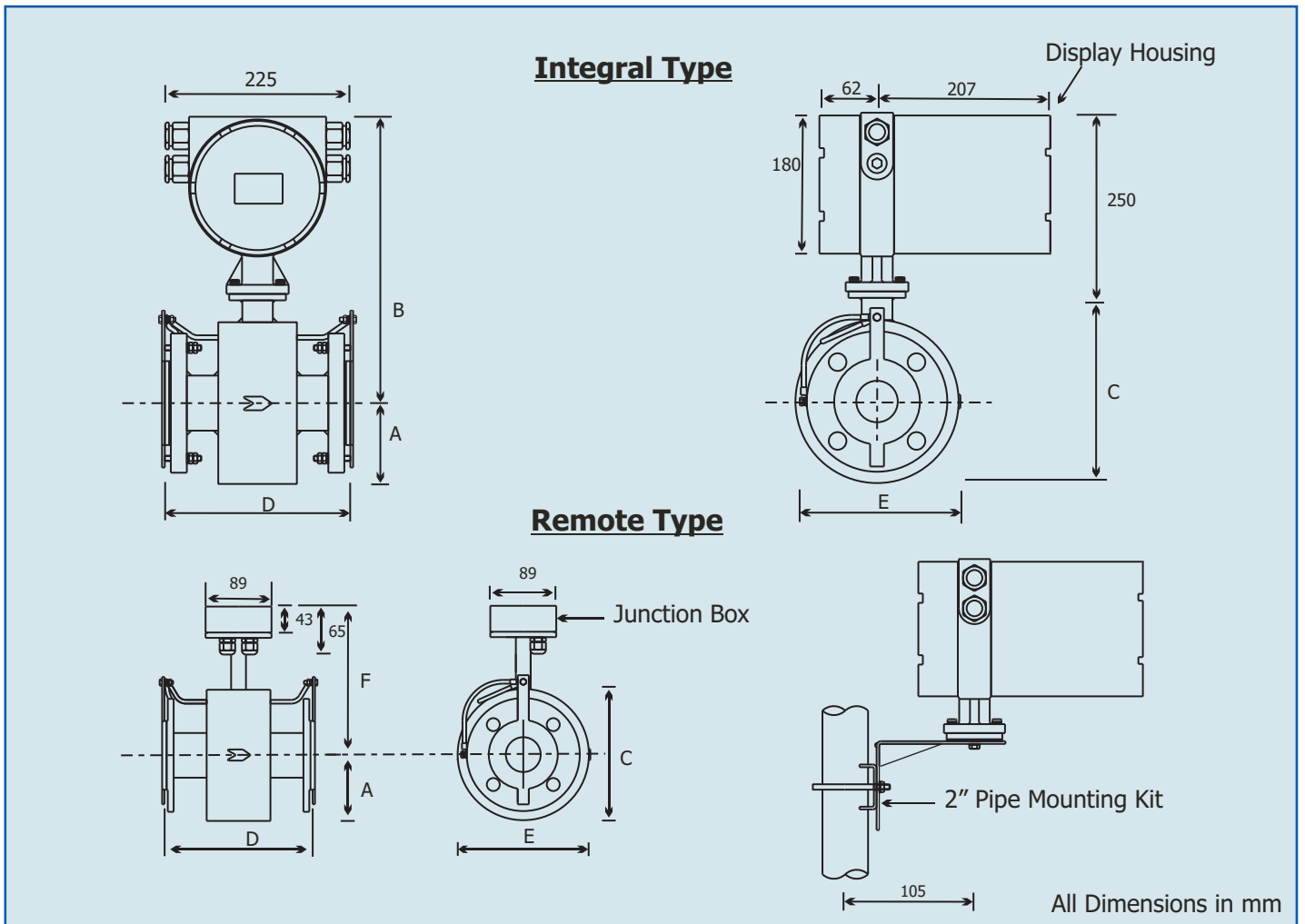

## Meter Dimensions in mm

DN (mm)	A	B	C	D	E	F
10, 15, 20	65	310	125	200	120	190
25, 32	80	325	155	200	150	205
40, 50	120	365	230	200	225	245
65, 80	130	375	250	200	245	255
100, 125	170	415	330	250	325	295
150	190	435	370	300	365	315
200	245	490	480	350	475	370
250	295	540	580	400	575	420
300	335	580	660	500	655	460
350	360	605	710	500	705	485
400	395	640	780	600	775	520
450	430	675	855	600	850	555
500	465	710	925	600	920	590
600	550	795	1090	600	1085	675

Notes : 1. Above dimensions are with ANSI 150 / DIN PN 16 flanges ( For other flanges - Consult Factory )  
 2. Add total 6mm for two earthing / Linear protection rings to dimension 'D'

R-1 A, VILAS APPT, SANT TUKARAM  
 PATH, KOPRI, THANE(E) 400 603, INDIA  
 Fax: 91-22-2532 4845

®

## SPINK CONTROLS

Phone: 91-22-2532 8223/24      Email: info@spinkcontrolsindia.com  
 www.spinkcontrols.com      www.spinkcontrolsindia.com

# Electromagnetic Flowmeter 6500

## MagProbe 6510 (Insertion Type)

### Measuring your Liquid Flow

---



---

### Introduction

Series 6500 is a new range of Bipolar Pulsed DC Insertion Type Electromagnetic Flowmeter. It is suitable for pipes with nominal diameters of 100 mm & above. The Flowmeter is based on Faraday's law of Electromagnetic Induction.

Series 6500 has excellent accuracy and flow rangeability within its class. The meter is suitable for use on wide range of corrosive and aggressive range of conductive liquids.

### Salient Features

- Based on Faraday's law of electromagnetic induction.
- Suitable for pipe sizes of diameters 100 mm & above
- With or without Integral Transmitter.
- Use of Isolating Ball Valve and Pressure Seal arrangement permits ease of mechanical Insertion and removal without disturbing the flow
- Absolute zero stability and noise elimination due to pulse D.C. excitation
- Measurement independent of liquid properties
- Optional inbuilt potentiometer provides full scale flow rate adjustments.
- Negligible pressure loss.
- Maintenance free design due to absence of any moving parts.
- Display of flow rate directly in user specified engineering units

### Applications

- Water Supply Networks
- Chemical and Process Industries
- Pharmaceutical Industry
- Waste - Water Management
- Sugar, Food and Beverages Industries
- Effluent Treatment Plants

# Operations

Electromagnetic Flowmeters are based on Faraday's law of Electromagnetic Induction.

In a Electromagnetic Flowmeter, magnetic field is generated by a set of coils. As the conductive liquid passes through the electromagnetic field, an electric voltage is induced in the liquid, which is directly proportional to its velocity. This induced voltage is perpendicular to both the liquid flow direction and the electromagnetic field direction. The voltage sensed by the electrodes is further processed by the transmitter to give standardised output signal or displayed in appropriate Engineering Units on LED Display.

The flux density of the electromagnetic field in a given Flowmeter and the distance between the electrodes are constant, therefore, the induced voltage is only a function of liquid velocity.

$E = K.B.\bar{v}.D$  where E : Induced voltage  
 K : Flow Tube Constant  
 B : Magnetic field velocity  
 $\bar{v}$ : Mean flow velocity  
 and D : Electrode Spacing

Volume flow is calculated by equation :

$$Q = \bar{v}.D.^2 \cdot \frac{\pi}{4}$$

Therefore,  $Q = \frac{E.D. \cdot \pi}{K.B.4}$

The induced voltage is not affected by the physical properties of liquid like temperature, viscosity, pressure, density and conductivity, as long as conductivity of the measure liquid is above minimum threshold level. For reliable measurement the pipe must be completely full of liquid.

The electromagnetic field coil assembly is excited by pulsed DC technique, which eliminates the interfering noise and provides automatic zero correction.

# Specifications

Suitable for Pipe Sizes	:	DN 100 to DN 2000
Media Conductivity (Min.)	:	10 $\mu$ S/cm (Consult factory for 5 $\mu$ S/cm)
Media Pressure	:	Upto 15 kg/cm <sup>2</sup>
Media Temperature (PTFE)	:	0°- 75°C
Ambient Temperature Range	:	0°- 50°C
Materials : Pipe	:	SS 316 (Non - magnetic)
Wetted Parts	:	PTFE (Teflon), SS 316
Electrode	:	SS 316 / Hastelloy C / Ta / Ti / Pt
Weld in Socket with flange	:	Carbon Steel
Connecting flanges	:	Carbon Steel
Transmitter	:	Cast Aluminium (LM6) , Epoxy painted
Mounting	:	Using a 2" Ball Valve Assembly
Power Supply	:	110 / 240V AC $\pm$ 15%, 50Hz
Power Consumption	:	20 VA
Cable Gland Entry	:	1/2" NPT (F)
Analog Output (Isolated)	:	4-20 mA DC / 0-20 mA DC
Pulsed Output (Optional)	:	Low Pulsed Rate Output 10 to 36000 pulses per hour a) Output to drive directly external electromagnetic counter of 12/24V DC @ 200 mA capacity OR b) Open Collector Output , High Pulse Rate Output, 0.5 KHz/1 KHz/10KHz/ (Open Collector Output)
Communication Port (Optional)	:	RS - 232 / RS - 485 MODBUS RTU Protocol
Maximum Load Resistance	:	1000 $\Omega$
Response Time	:	10 seconds
Flow Velocity Range	:	0.3 to 10 m/s
Ingress Protection	:	IP - 65 for Flow Transmitter and IP-68 for Sensor Assembly
LED Display	:	4 Digit Indication for Flow Rate and 8 Digit Indication for Totaliser Programming from Front Keyboard for Engineering Units
Accuracy	:	$\pm$ 2% of Span
For Flow between 0 to 100%	:	Refer Error Diagram
Reference Conditions	:	
Power Supply	:	Nominal
Ambient Temperature	:	2 $\text{S}$ $\pm$ 2 C
Load Resistance	:	500 $\Omega$
Repeatability	:	$\pm$ 0.2% of span
Effect of Ambient Temperature	:	Less than 0.2% per 10°C
Effect of Power Supply	:	Less than 0.1% per 10% Voltage variation
Effect of Load Resistance	:	Less than 0.1% of span

## Error Diagram :

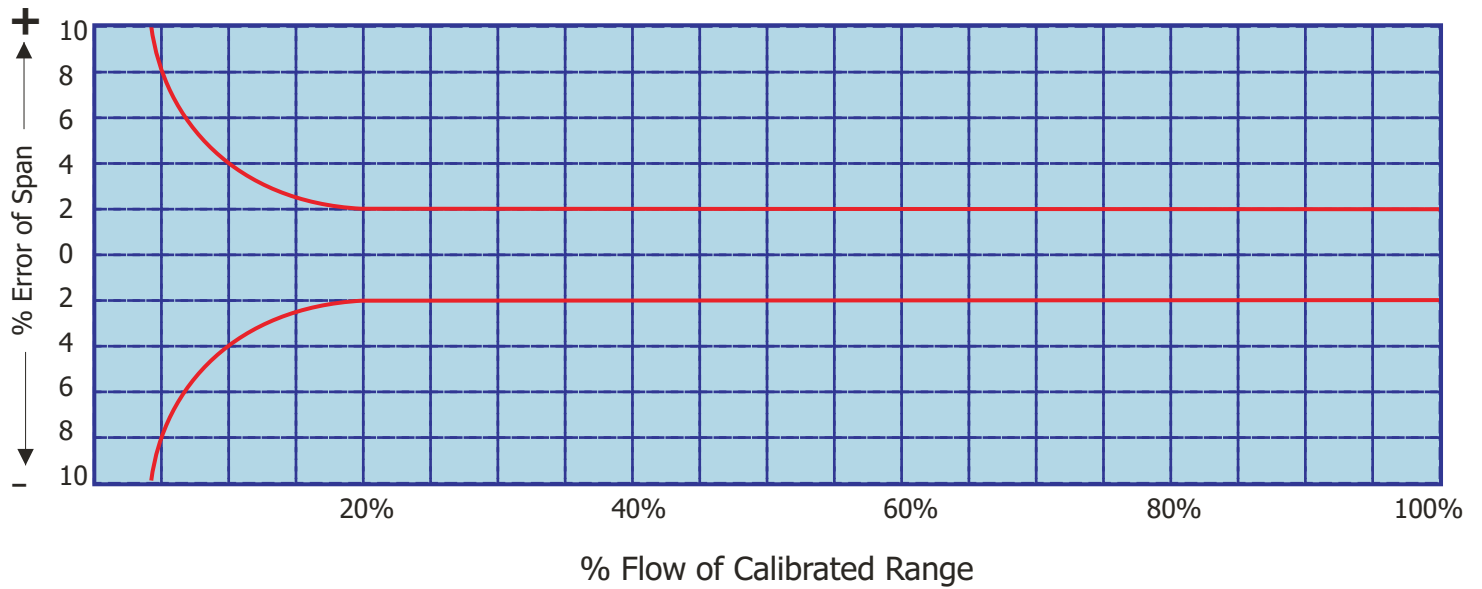

## Flow Rate Table

Flow Rate at  $V = 1$  m/Sec.

DN	m <sup>3</sup> /Hr	LPM	LPS
100	28.27	471.2	7.9
150	63.61	1060.1	17.7
200	113.08	1884.7	31.4
250	176.69	2944.8	49.1
300	254.43	4240.5	70.7
350	346.31	5771.8	96.2
400	452.32	7538.7	125.6
500	706.75	11779.2	196.3
600	1017.72	16962.0	282.7
700	1385.23	23087.2	384.8
800	1809.28	30154.7	502.6
900	2289.87	38164.5	636.1
1000	2827.00	47116.7	785.3
1200	4070.88	67848.0	1130.8
1400	5540.92	92348.7	1539.2
1600	7237.12	120618.7	2010.3
1800	9159.48	152658.0	2544.3
2000	11308.00	188466.7	3141.1

### NOTES :

- 1) A Ball Valve Assembly with Socket Flange will be supplied in advance. Socket Flange is to be welded onto the Pipe Line for Flowmeter installation. This will enable you to install the Flowmeter even if the line is charged.
- 2) A minimum 10 D upstream and 5D downstream straight lengths should be maintained at installation location. where D is the pipe diameter. The Flowmeter installation location should be free of bends, elbows, tees, valves etc.
- 3) Installation location should be such that the pipe will be always full with water and in no case it should be partially filled.

# Dimensional Drawing :

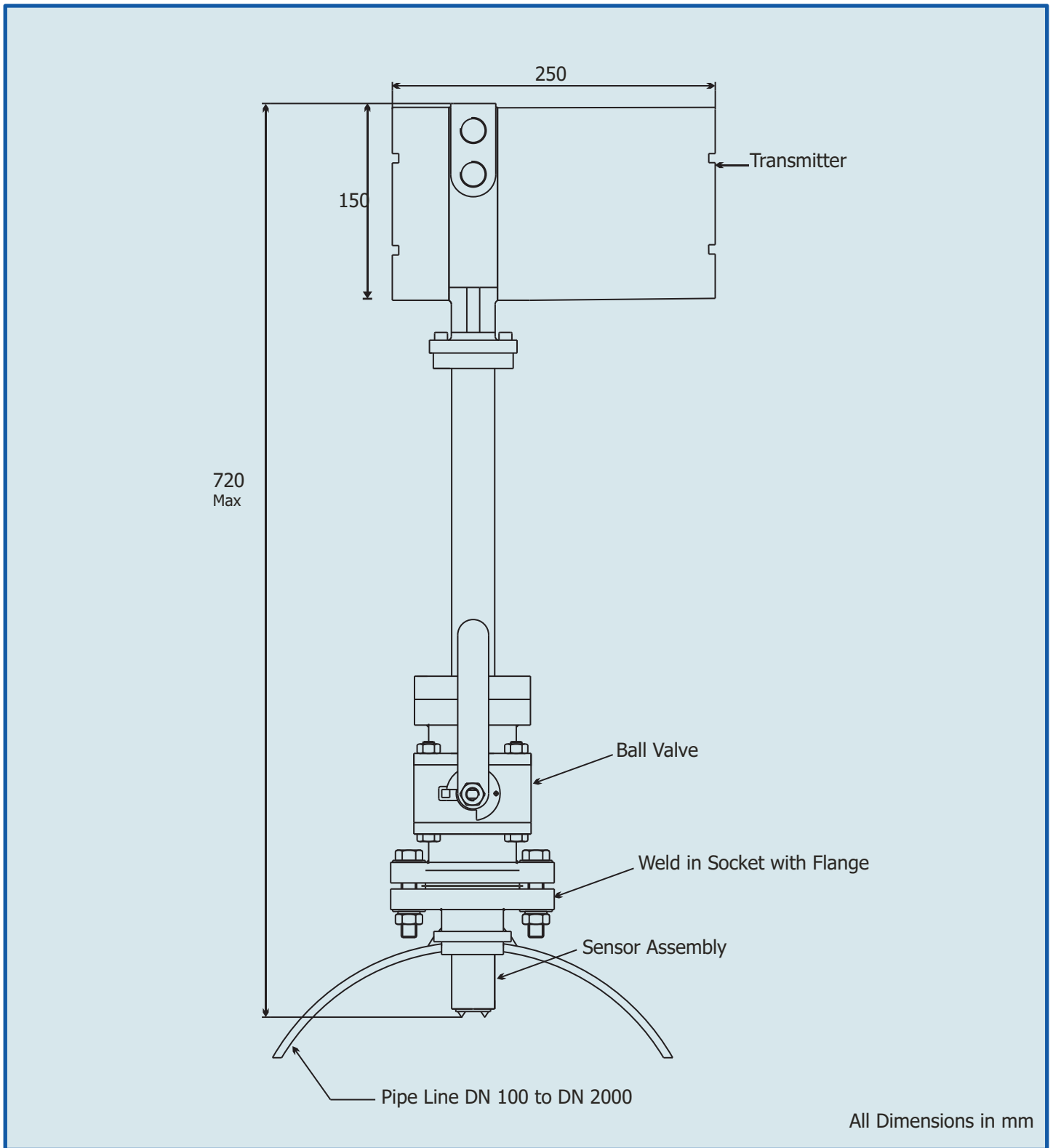

R-1 A, VILAS APPT, SANT TUKARAM  
PATH, KOPRI, THANE(E) 400 603, INDIA  
Fax: 91-22-2532 4845

# ORI FLOW METER

THE ORI-FLOW METER MEASURES FLOW BY INSERTING AN ORIFICE AT PART OF THE PIPING, GENERATING DIFFERENTIAL PRESSURE BEFORE AND BEHIND THE ORIFICE BY MEANS OF THE FLOW, AND EXTRACTING THIS DIFFERENTIAL PRESSURE BY A SUITABLE METHOD.

DIFFERENTIAL PRESSURE ( $P_1-P_2$ ) OF MAIN ORIFICE AND THE FLOW Q HAVE SHOWN IN EQUATION GIVEN BELOW. THE FLOW IS PROPORTIONAL TO THE SQUARE ROOT OF THE DIFFERENTIAL PRESSURE.

$$Q = CF \sqrt{\frac{2g}{\rho} (P_1 - P_2)}$$

- Q : Volumetric flow  
 C : Flow co-efficient  
 F : Cross sectional area of orifice hole  
 g : Acceleration of gravity  
 $P_1-P_2$  : Differential pressure  
 ? : Specific weight of fluid

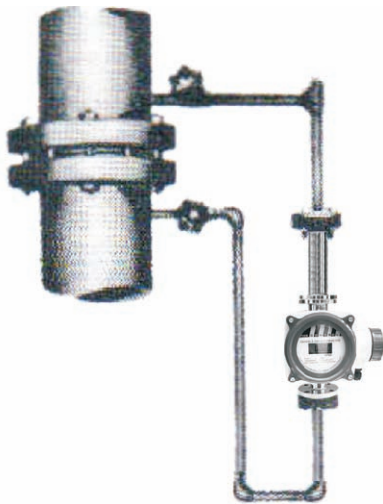
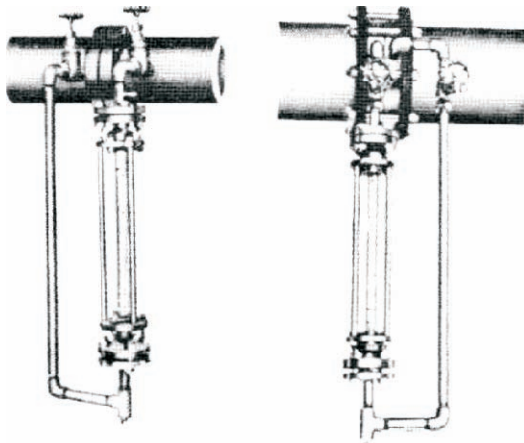
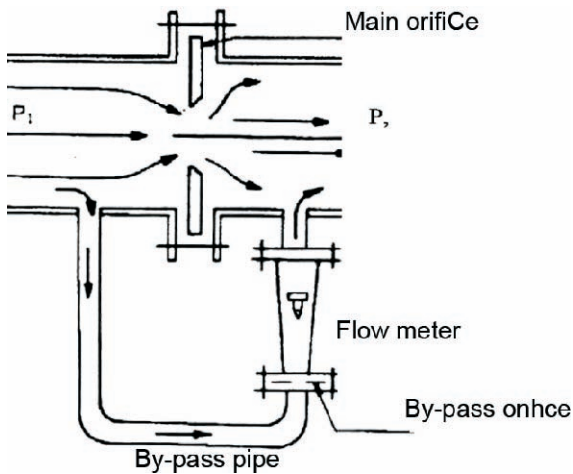

The generated differential pressure is sent to a manometer or other differential pressure gauge and a differential flow meter can be formed by attaching a flow scale to this gauge. However, since the flow indication is a square root scale reading is difficult. Moreover, incase of remote transmission it is inconvenient because the evolution operation is performed to obtain linear relation.

Therefore if a by - pass pipe connecting the before and behind point of the main orifice is installed and the flow is branched to that pipe to overcome these disadvantage, that flow becomes proportional to the differential.

## Capacity Guide Maximum m<sup>3</sup>/h of Water.

Main Pipe Size		Main Pipe Maximum Flow m/h (20°C Water)					
		Differential Pressure					
Inch	Millimeter	1000mmWC	1500 mmWc	2000mmWc	2500 mmWC	3000mmWC	500mmWC
2	50	67-19	82-23	9.4-27	10.5 - 30	11.5 - 34	15 - 42
2 ½	65	11-32	13-38	16-45	17 - 50	19 - 55	27 - 170
3	80	15-44	19-54	22-63	24 - 70	27 - 78	35 - 100
4	100	26-76	32-92	37-100	42 - 120	46 - 130	59 - 165
5	125	41-110	50-140	58-160	64 - 180	70 - 200	91 - 225
6	150	57-160	70-200	81-230	91 - 260	99 - 280	128 - 350
8	200	100-280	122-350	140-420	160 -450	170-500	220 - 610
10	250	150-440	190-540	220-630	240 - 700	270-780	340 - 930
12	300	220-640	270-780	310-900	350-1000	380-1100	490-1300
14	350	270-780	340-950	390-1100	430-1250	480-1350	610-1600
16	400	360-100	440-1200	510-1400	570-1600	630-1800	810-2100
18	450	460-1300	570-1600	650-1800	730-2100	800-2300	1040-2700
20	500	580-1600	710-2000	820-2300	910-2600	1000-2900	1300-3400

R-1 A, VILAS APPT, SANT TUKARAM  
 PATH, KOPRI, THANE (E) 400 603, INDIA  
 Fax: 91-22-2532 4845

**SPINK CONTROLS** ®

Phone: 91-22-2532 8223/24  
 www.spinkcontrols.com

Email: info@spinkcontrolsindia.com  
 www.spinkcontrolsindia.com

# ORIFICE PLATE ASSEMBLY

THE ORIFICE PLATE WITH FLANGE ASSEMBLIES ARE EMPLOYED FOR MEASURING THE RATE OF FLOW OR QUANTITY OF MOVING FLUIDS LIKE LIQUIDS, GASES OR VAPOURS.

THE ORIFICE PLATES ARE DESIGNED AS PER Bs 1042-1981 / ISO 5167 & L.K. SPINK STANDARDS. WHEN A DEVICE SUCH AS AN ORIFICE PLATE IN A PIPE LINE THROUGH WHICH A FLUID IS FLOWING, AS STATIC PRESSURE DIFFERENCE EXISTS BETWEEN THE UPSTREAM SIDE & THE DOWNSTREAM SIDE OF THE DEVICE IS GEOMETRICALLY SIMILAR TO ONE ON WHICH DIRECT CALIBRATION HAS BEEN MADE, THE CONDITIONS OF USE BEING THE SAME, THE RATE OF FLOW MAY BE DETERMINED FROM A KNOWLEDGE OF THE CIRCUMSTANCE UNDER WHICH THE DEVICE IS BEING USED.

## TECHNICAL SPECIFICATION

ORIFICE PLATE	:	SS 316/ SS 304/ MONEL/SUIT TO CUSTOMER'S REQUIREMENT
LINE SIZE	:	15 NB TO 600 NB
FLANGES	:	ASTM-A-105/A182 /SS 316/SS 304/ MONEL/ SUIT TO CUSTOMER'S REQUIREMENT
OPTIONAL	:	IBR APPROVED FLANGES
TYPE OF FLANGES	:	WELD NECK /SLIPON /SOCKET- WELD
TYPE OF TAPPING	:	FLANGE TAPS /CORNER TAPS/ RADIUS TAPS
SIZE OF TAPS	:	1/2 INCH NPT (F)
STUDS / BOLTS	:	ASTM-A-193 GR B7
NUTS	:	ASTM-A-193 GR 2H
GASKET	:	SPIRAL WOUND/CAF/ TEFLON



R-1 A,VILAS APPT, SANT TUKARAM  
PATH,KOPRI, THANE(E) 400 603,INDIA  
Fax: 91-22-2532 4845

**SPINK CONTROLS**®

Phone:91-22-2532 8223/24  
www.spinkcontrols.com

Email:info@spinkcontrolsindia.com  
www.spinkcontrolsindia.com

# ORIFICE PLATE ASSEMBLY

THE ORIFICE PLATE WITH FLANGE ASSEMBLIES ARE EMPLOYED FOR MEASURING THE RATE OF FLOW OR QUANTITY OF MOVING FLUIDS LIKE LIQUIDS, GASES OR VAPOURS.

THE ORIFICE PLATES ARE DESIGNED AS PER Bs 1042-1981 / ISO 5167 & L.K. SPINK STANDARDS. WHEN A DEVICE SUCH AS AN ORIFICE PLATE IN A PIPE LINE THROUGH WHICH A FLUID IS FLOWING, AS STATIC PRESSURE DIFFERENCE EXISTS BETWEEN THE UPSTREAM SIDE & THE DOWNSTREAM SIDE OF THE DEVICE IS GEOMETRICALLY SIMILAR TO ONE ON WHICH DIRECT CALIBRATION HAS BEEN MADE, THE CONDITIONS OF USE BEING THE SAME, THE RATE OF FLOW MAY BE DETERMINED FROM A KNOWLEDGE OF THE CIRCUMSTANCE UNDER WHICH THE DEVICE IS BEING USED.

## TECHNICAL SPECIFICATION

ORIFICE PLATE	:	SS 316/ SS 304/ MONEL/SUIT TO CUSTOMER'S REQUIREMENT
LINE SIZE	:	15 NB TO 600 NB
FLANGES	:	ASTM-A-105/A182 /SS 316/SS 304/ MONEL/ SUIT TO CUSTOMER'S REQUIREMENT
OPTIONAL	:	IBR APPROVED FLANGES
TYPE OF FLANGES	:	WELD NECK /SLIPON /SOCKET- WELD
TYPE OF TAPPING	:	FLANGE TAPS /CORNER TAPS/ RADIUS TAPS
SIZE OF TAPS	:	1/2 INCH NPT (F)
STUDS / BOLTS	:	ASTM-A-193 GR B7
NUTS	:	ASTM-A-193 GR 2H
GASKET	:	SPIRAL WOUND/CAF/ TEFLON

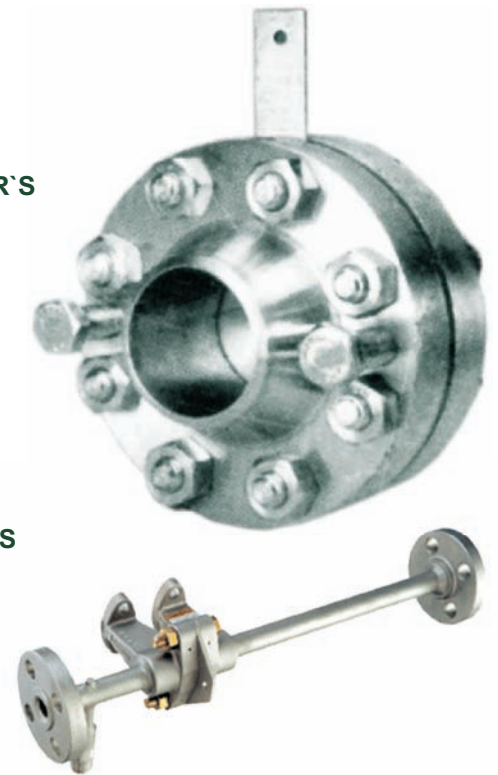

R-1 A,VILAS APPT, SANT TUKARAM  
PATH,KOPRI, THANE(E) 400 603,INDIA  
Fax: 91-22-2532 4845

**SPINK CONTROLS**®

Phone:91-22-2532 8223/24  
www.spinkcontrols.com

Email:info@spinkcontrolsindia.com  
www.spinkcontrolsindia.com