

**ROTOLOK**

everything under control...

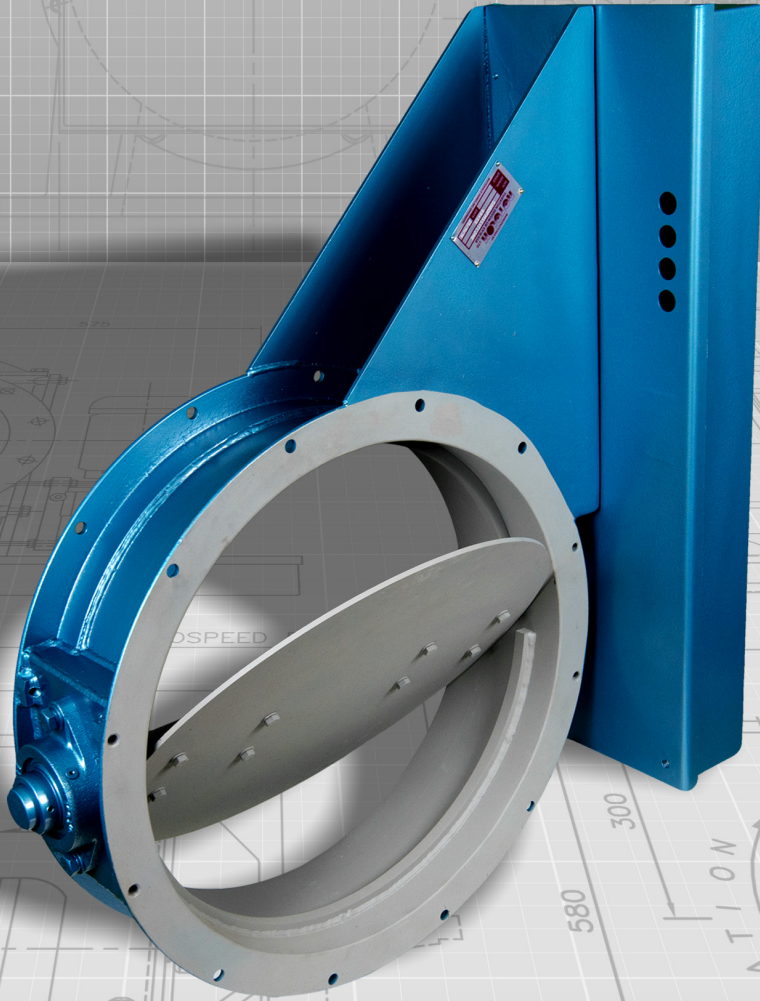

# BUTTERFLY DAMPERS

**ROTOLOK USA**

Industrial Ventures II  
2711 Gray Fox Road  
Monroe  
North Carolina  
28110  
United States of America  
Tel: +1 (704) 282 4444  
Fax: +1 (704) 282 4242  
[www.rotolok.us](http://www.rotolok.us)  
[sales@rotolok.us](mailto:sales@rotolok.us)



## INTRODUCTION

The fabricated range of Rotolok Butterfly Dampers are used extensively in the air and dust handling industries generally in fan systems.

They are normally operated remotely by air cylinders, electric or pneumatic actuators although manual versions through the customary hand lever, hand-wheel and reduction gearboxes can also be accommodated.

## SPECIFICATION

Construction is generally from Mild or Stainless Steel with the body of the valve formed from rolled steel angles or channels dependent on the size.

The Damper itself is formed from two plates which sandwich, if required, a felt seal or alternatively it can be a single blade sized for close fitment to the valve body. The type selected is dependent on the amount of air leakage that can be accepted.

The split spindle mounting system minimizes turbulence within the air stream and these spindles are mounted on either two or four bolt flange mounted sealed for life bearings.

Seals can be fitted if required through a simple 'O' ring or, on high temperature applications, the conventional stuffing box is utilised.

The type of actuator, to suit the clients requirements or specification, can be added to all sizes and, on pneumatic versions, limit switches and single solenoid spring return valves are included.

## RANGE

With fabrication, practically any size can be accommodated to suit the duct size with flanges also made to suit system designers needs.

The range starts at 14" diameter and extends to 59" in diameter. Standard sizes are as shown in the chart below. Square units and special sizes can, and have, been supplied.

On valve size selection it is important to ensure that the ducting size is equal to or slightly larger than the valve. This is to prevent any possible interference during the damper operation in the area where the blade enters the ducting, or should there be any misalignment between the components on assembly.

## BUTTERFLY DAMPER

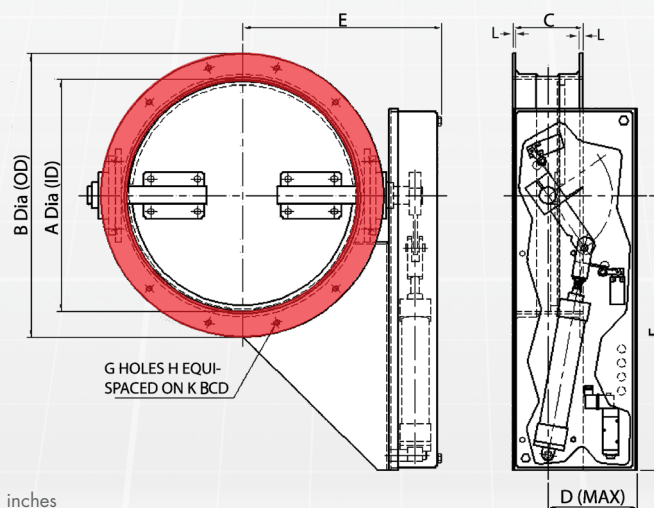

All dimensions are in inches

SIZE	A	B	C	D	E	F	G	H	K	L
16"	16"	19 1/2"	5 1/8"	8"	14 5/8"	23 1/4"	12	3/8"	18 1/4"	1/4"
18"	18"	21 1/2"	5 1/8"	8"	15 5/8"	23 1/4"	12	3/8"	20 1/4"	1/4"
20"	20"	24 5/16"	5 7/8"	8"	17 1/8"	23 1/4"	12	1/2"	22 5/8"	1/4"
24"	24"	28 3/8"	5 7/8"	8"	19 1/8"	23 1/4"	16	1/2"	26 5/8"	1/4"
28"	28"	32 3/8"	5 7/8"	8"	21 1/8"	23 1/4"	16	1/2"	30 5/8"	1/4"

Dimensions are approximate and subject to change without notice  
 Planning-in detail for general guidance only  
 (To cover safety aspects ask for our safety leaflets)  
 Drillings are Rotolok standards. Variations can be made.

