

# Needle Valve

## Forged Body Needle Valve



Our clients can avail from us a We are the manufacturers of a wide range of **High Pressure Needle Valve**. Their reliability and power-packed performance make these valves a segment leading product. We offer **High Pressure Needle Valve** in diverse specifications and sizes to match the precise requirements of the clients. Some of the key details of our products include:

Size:- 1/4"(M/F) To 1/2"(M/F)

VAVLE DIMENSIONS(Dimension in mm)				
Size	8	10	15	20
A	52	52	58	58
D	92	92	97	97
E	25	25	30	
C	52	52	55	55
H	4.5	5	5.5	6

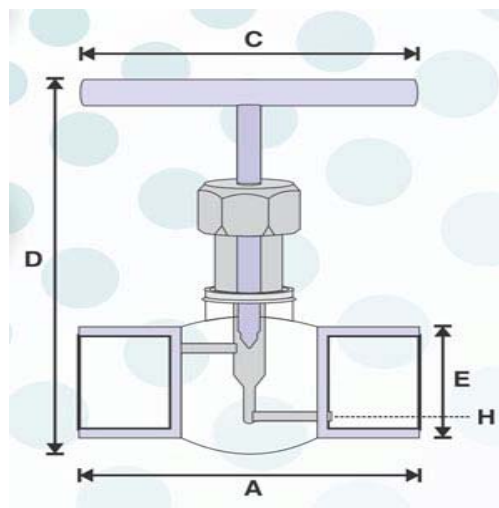

PART/MATERIALS LIST	
Body	304(CF8) 316(CF8M)
Spindal	304
Handle	304
Gland packing	P.T.F.E

TEST PRESSURE(PSTI/KG)	
Testing	6000 PSTI / 420 KG
thread	BSP & NPT for requirement

## IC Needle Valve



The comprehensive range of reducing sockets offered by us has earned huge accolades for its maintenance free life. It is has been designed under the strict supervision of our expert professionals, who ensure the range offered by us exceeds the expectations of the clients. Our range plays an important role in reducing the outlet size of a male fitting and in creating a smaller female fitting. The key specifications of our products include

Technical Specification					
Size	L	D	Size	L	D
1/8"	25	21	1 1/4"	47	49
1/4"	30	21	1 1/2"	49	56
3/8"	30	23	2"	57	69
1/2"	36	26	2 1/2"		
3/4"	38	33	3"		
1	42	39	4"		

